

# StepArray

# SA180S

DGRC Multi channel Steerable Column Loudspeaker

StepArray column loudspeakers ensure perfect speech intelligibility and optimal acoustic comfort, even in noisy and reverberant venues. They are based on the DGRC (Digital & Geometric Radiation Control) principle patented by Active Audio

Compared with a classic sound system in which each loudspeaker is controlled independently, the DGRC makes it possible to decrease the number of channels to be controlled, thereby enhancing cost effectiveness.

It is possible to place the electronics outside the columns, which has the following key advantages:

- security: electronics can be placed in a secure room, with uninterruptible power supply (UPS)
- sharing of electronic between multiple columns
- easier installation and maintenance

The StepArray columns are driven by integrated processor MPA amplifiers. The amplifiers' DSP, managed via the Active Audio AMI software, enables real-time control of loudspeaker directivity, along with 12-band parametric equalization and a delay line, ensuring precise adaptation of the column's output to the room's acoustics and geometry.

In room acoustics, when column loudspeakers are highly directional, it is necessary to have several sizes of columns to fit all kind of venues.

The StepArray range offers a wide variety of listening area sizes and inclination to suit all situation.

Dedicated to step-seated audience, the SA 180S model delivers up to 97dB SPL with a nominal range of 30m.



- Max SPL : 97dB at 15m
- Bandwidth : 110Hz- 19kHz
- Continuous power : 220W
- IP54
- Paintable
- 5 years warranty
- For tilted audience plane

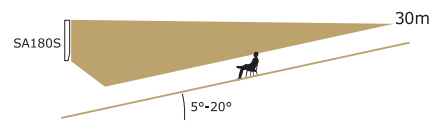

## DGRC principle

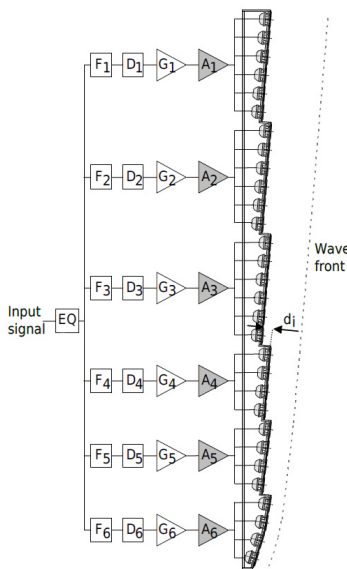

StepArray columns implement the DGRC line-array principle (Digital and Geometric Radiation control) which is a synthesis of geometric and electronic arrays patented by Active audio.

The key idea is to split the desired wave-front into sections and move them back on a vertical line, much like what is done in the Fresnel lenses used in optics. Then electronic delays are used to compensate sound propagation delay between the sections. It was shown in DGRC array that with this delay setting there is no diffraction at the edge of the saw-tooth shape. As a result of this principle, the number of DSP and amplification channels is independent of the number of loudspeakers, so that a dramatically reduced number of channels is achieved.

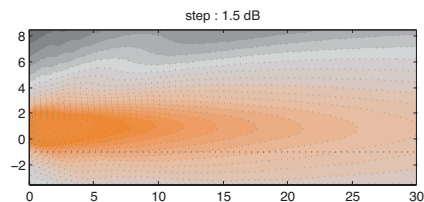

Step Array SA180S vertical directivity: sound level for the speech octaves (500Hz-1kHz-2kHz) in the vertical median plane.



# SA180S

## Technical Specifications

### Mechanical drawing

Front views

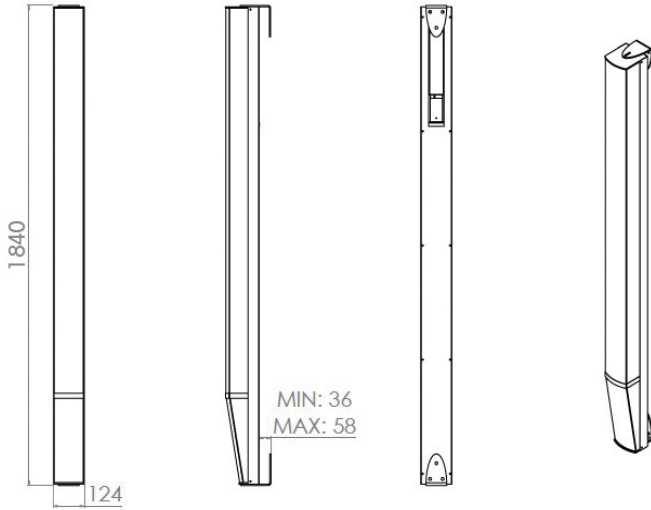

Rigging

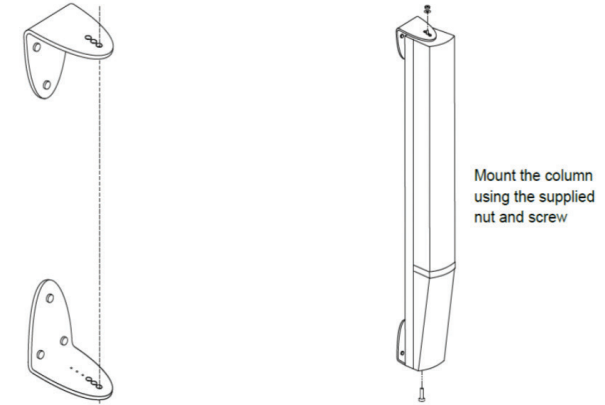

### Technical Specifications

#### Acoustical data

Range +/- 3dB	22 m
Range +/- 5dB	30 m
Max SPL	97dB at 15m (120,5dB at 1m)*
Angle of audience	>5°
Frequency bandwidth (-10 dB)	110Hz-19kHz
Horizontal opening angle (1 kHz)	180°
Loudspeaker	22 x3"

#### Mechanical data

Net weight	17 kg
Shipping weight	21 kg
Height	1840 mm
Width	124 mm
Depth	131 mm
Standard colors	White RAL 9016 Black RAL 9005

Sound level by octave in the axis of the listening plane in front of the column with respect to the distance from the column

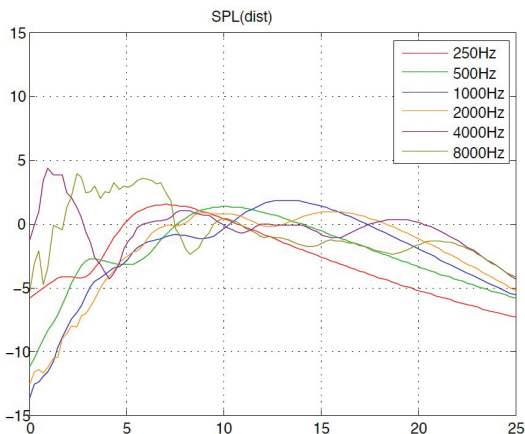

#### Electrical data

Input	12 Pins euroblock
Impedance	3 channels 8Ω
Cabling lenght	<300m with 4x1,5mm <sup>2</sup> cable <500m with 4x2,5mm <sup>2</sup> cable

#### Tunning and exploitation

Software supplied	AMI
Modeling	EASE and CATT Active Audio prediction software <a href="http://www.activeaudio.fr">www.activeaudio.fr</a>
Nominal mounting height	3,0 m

\*Estimated sound level based on a 6dB decreased by doubling distance from the measure pressure level at 15m.

#### Frequency response

StepArray frequency response. Average from 6 to 25m for a column at 2.55m height and an audience area tilted by 12°. In red: with bass high-pass on position «100Hz», In blue: with bass high-pass on position «200Hz»

